

SPECIAL PERMITTING COMMITMENTS

- McHenry County
 Require a minimum of a 4" duct to be used, boring at a minimum of 36" depth.
 Provide a proper IDOT approved traffic control plan.
 Min. 36" required outside of pavement crossings.
 Min. 30" for stormdrain crossings
 No open cut of a County Highway allowed.
 Lake in the Hills
 No specific requirements.

INDEX OF SHEETS

- CL Cover Sheet
- IN Index, General Notes, and Commitments Sheet
- TR Typical Details Sheet
- DZ Detail View, Installation Details Sheet
- LI Symbol Reference Legend Sheet
- POI Project Overview Map
- D1 - D5 Duct and Vault Installation Maps
- F1 - F5 Fiber Installation Maps
- DOT Highway Standards
- 701001-02 Off-Road Operations, 2L, 2W, More Than 15ft Away
- 701006-05 Off-Road Operations, 2L, 2W, 15ft To 24ft From Pavement Edge
- 701901-09 Traffic Control Devices

GENERAL PLAN NOTES

1. These notes shall be applicable to all operations performed under this contract, except when they conflict with any SPECIAL PERMIT COMMITMENTS (SEE THIS SHEET). In such cases, the notes in that section shall supercede these notes.
 All care should be taken to mitigate damage to existing utilities. OneCall shall be contacted before any boring or excavation.
2. Note that handholes drawn on the shared lot line can be adjusted to either side of the lot line as necessary, which is standard on i3Broadband prints. Handholes that are shifted to one side of a lot line need to be placed on that side of the lot line, generally to comply with an easement, or to avoid a driveway or large tree.
3. Construction change order requests shall be coordinated with the appropriate i3 Construction Department Representative and CLEARLY DOCUMENTED ON THESE PLANS AS RED-LINED AS-BUILT DRAWINGS.
4. Any damage to adjacent properties caused by construction operations within the work area shall be fully restored to their ORIGINAL CONDITION.
5. Dimensions (approximate, in feet) shown generally indicate total Right-of-Way width, or Utility Easement width relative to nearest lot line. Rights-of-Way and Utility Easements are not necessarily uniform (i.e. not split evenly a cross street centerline or property line). Contact i3 as needed for clarity.
6. SLACK NOTES:
 -All taps are to have 4' of slack at the head, 55' at the splice case, and no slack storage anywhere else.
 -Mainline cable to have 55' at all ends/cut points and 110' at all #3 or larger handholes where cable is uncut.
 -Any other abnormalities will be noted on prints.
7. The CONTRACTOR shall be required to comply with all Federal, State, and Local laws/ordinances, in addition to all i3broadband contract documents.

SUBMITTED FOR PERMITTING

TYPICAL VAULT (HANDHOLE) DETAILS

RESERVED
 FOR SHEET
 NORTH ARROW
 AND SCALE

PROJECT ENGINEER:
 Troy Mosiman

REVISIONS

| | | | | | |
|---|---|----|--|-----|--|
| / | / | Z4 | | No. | |
| / | / | Z4 | | No. | |
| / | / | Z4 | | No. | |
| / | / | Z4 | | No. | |
| / | / | Z4 | | No. | |

PROPOSED FIBER INSTALLATION PLANS
 TYPICAL VAULT (HANDHOLE) DETAILS
 Printed: 4/2/2025
 Time: 3:31 PM

SECTOR: NWCHIL2068

SHEET:
DT1

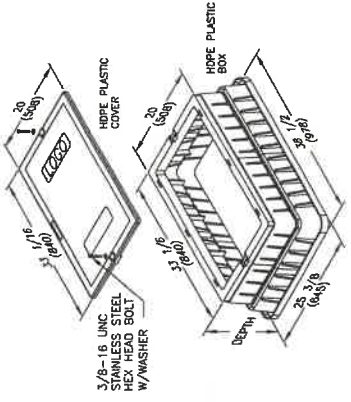

HH1 (PED RATED) (PE-14 or Eq.)

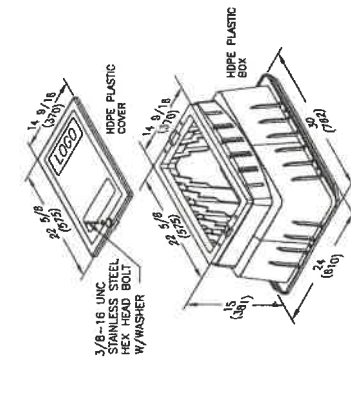

HH2 (PED RATED) (PE-20 or Eq.)

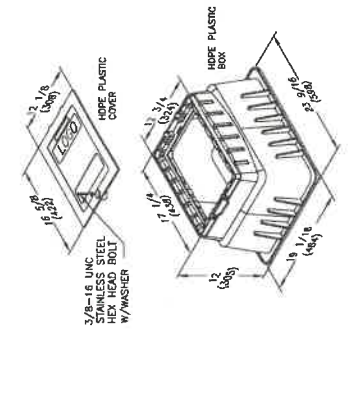

HH3 (PED RATED) (PE-30 or Eq.)

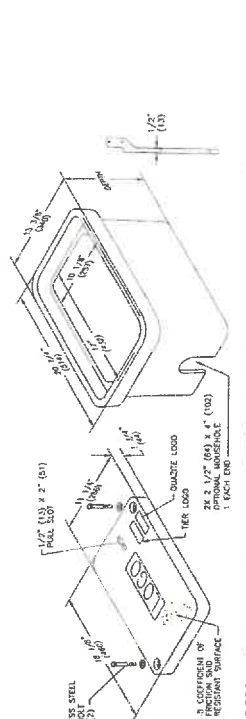

HH0 (TIER15 RATED)

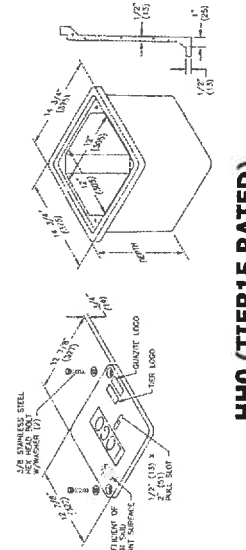

HH1 (TIER15 RATED) (QUAZITE 11x18 or Eq.)

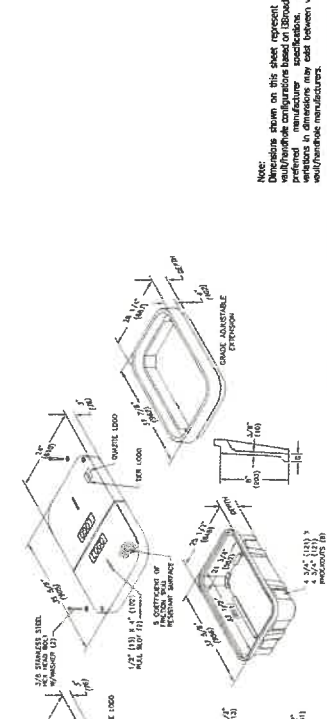

HH2 (TIER15 RATED) (QUAZITE 17x30 or Eq.)

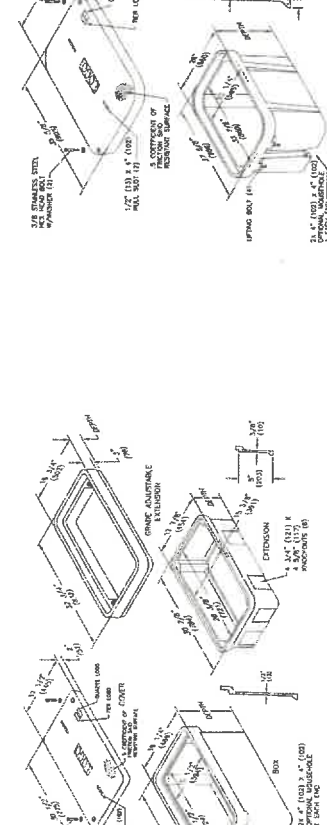

HH3 (TIER15 RATED) (QUAZITE 24x36 or Eq.)

Note:
 Dimensions shown on this sheet represent typical dimensions. Actual dimensions may vary based on manufacturer specifications. Minor variations in dimensions may exist between various manufacturer manufacturers.

SUBMITTED FOR PERMITTING

HH6 (TIER15 RATED) (QUAZITE 24x36 or Eq.)

HH3 (TIER15 RATED) (QUAZITE 17x30 or Eq.)

SYMBOL REFERENCE LEGEND

CONSTRUCTION

- Duct/Conduit**
- Primary
 - Secondary
 - Third Order
 - In Building
 - All other values
- Shelters**
- Shelters
- Cabinets**
- Cabinets
- Vaults/Handholes**
- Pedestrian Rated**
- Unknown Size (Pedestrian)
 - HH 0 (12x12 or eq.)
 - HH 1 (PE-14 or eq.)
 - HH 2 (PE-20 or eq.)
 - HH 3 (PE-30 or eq.)
 - HH 4 (2x3 or eq.)
- Tier 15 Rated**
- Unknown Size (Tier Rated)
 - HH 0 (12x12 or eq.)
 - HH 1 (PE-14 or eq.)
 - HH 2 (PE-20 or eq.)
 - HH 3 (PE-30 or eq.)
 - HH 4 (2x3 or eq.)
 - HH 5 (4x4 or eq.)
 - HH 6 (4x4 or eq.)
 - HH 7 (4x4 or eq.)
 - HH 8 (4x4 or eq.)
 - HH 9 (4x4 or eq.)
 - HH 10 (4x4 or eq.)
 - HH 11 (4x4 or eq.)
 - HH 12 (2x4 or eq.)
 - HH 13 (2x4 or eq.)
 - HH 14 (2x4 or eq.)
 - HH 15 (2x5 or eq.)
 - HH 16 (2x5 or eq.)
 - HH 17 (2x5 or eq.)
 - HH 18 (4x4 or eq.)
 - HH 19 (4x4 or eq.)
- Unknown/Other**
- Unknown Type/Size (3 Owned, See Notes)
- Building Terminations (OPDCs)**
- Building Terminations (OPDC)
- Cable Terminations**
- Cable Terminations
- Duct Terminations**
- Buried Endcap
 - Stubbed Above Ground (Bkg. Termination)
 - Wall Box
 - Other/Unknown

INSTALLED

- Duct/Conduit**
- Primary
 - Secondary
 - Third Order
 - Fourth Order
 - In Building
 - All other values
- Shelters**
- Shelters
- Cabinets**
- Cabinets
- Vaults/Handholes**
- Pedestrian Rated**
- Unknown Size (Pedestrian)
 - HH 0 (12x12 or eq.)
 - HH 1 (PE-14 or eq.)
 - HH 2 (PE-20 or eq.)
 - HH 3 (PE-30 or eq.)
 - HH 4 (2x3 or eq.)
 - HH 5 (4x4 or eq.)
- Tier 15 Rated**
- Unknown Size (Tier Rated)
 - HH 0 (12x12 or eq.)
 - HH 1 (PE-14 or eq.)
 - HH 2 (PE-20 or eq.)
 - HH 3 (PE-30 or eq.)
 - HH 4 (2x3 or eq.)
 - HH 5 (4x4 or eq.)
 - HH 6 (2x3 or eq.)
 - HH 7 (2x4 or eq.)
 - HH 8 (2x5 or eq.)
 - HH 9 (2x5 or eq.)
 - HH 10 (4x4 or eq.)
 - HH 11 (4x4 or eq.)
- Unknown/Other**
- Unknown Type/Size (3 Owned, See Notes)
- Third Party Vaults/Handholes**
- Bkg. (Memory Key) Handhole
 - Struck Handhole
 - 3rd Party (All Other)
- Fiber Manholes**
- AT&T Manhole
 - Fiber Optic Manhole
- Building Terminations (OPDCs)**
- Building Terminations (OPDC)
- Cable Terminations**
- Cable Terminations
- Duct Terminations**
- Buried Endcap
 - Stubbed Above Ground (Bkg. Termination)
 - Wall Box
 - Other/Unknown
- Duct Field Repairs**
- Duct Field Repairs

MISC.

- Utility Easement**
- Utility Easement
- Parcels**
- Duct end Vault Installation Neps
 - Field Installation Neps
- Sector Boundaries**
- Cover & Liner: Main Project
 - Index Map (All)
- Project Sector**
- Project Sector
- Non Project Sectors**
- Non Project Sectors
- Drop Arrows**
- Drop Arrows (Visible)
- Index Sheet Borders**
- Project Sheet Borders

- Splice Cases**
- Type A
 - Starlighter 3000
 - 3M
 - Type B
 - In Building
 - Type C
 - Capote
 - Type D
 - Type E (No Grounding)
 - Color (Field Repair)
- Internal Taps**
- 2 Ports
 - 4 Ports
 - 6 Ports
 - 8 Ports
 - 12 Ports
- Splitters**
- Click
 - Zone
 - Unknown
- Additional Cable Stack**
- Additional Cable Stack
- Taps**
- 2 Ports
 - 4 Ports
 - 6 Ports
 - 8 Ports
 - 12 Ports
- Mainline Cables**
- 11
 - 4'
 - 6'
 - 8'
 - 12'
 - 24'
 - 48'
 - 72'
 - 96'
 - 144'
 - 216'
 - 288'
 - 432'

- Splice Cases**
- Type A
 - Starlighter 3000
 - 3M
 - Type B
 - In Building
 - Type C
 - Capote
 - Type D
 - Type E (No Grounding)
 - Color (Field Repair)
- Internal Taps**
- 2 Ports
 - 4 Ports
 - 6 Ports
 - 8 Ports
 - 12 Ports
- Splitters**
- Click
 - Zone
 - Unknown
- Additional Cable Stack**
- Additional Cable Stack
- Taps**
- 2 Ports
 - 4 Ports
 - 6 Ports
 - 8 Ports
 - 12 Ports
- Mainline Cables**
- 11
 - 4'
 - 6'
 - 8'
 - 12'
 - 24'
 - 48'
 - 72'
 - 96'
 - 144'
 - 216'
 - 288'
 - 432'

- Splice Cases**
- Type A
 - Starlighter 3000
 - 3M
 - Type B
 - In Building
 - Type C
 - Capote
 - Type D
 - Type E (No Grounding)
 - Color (Field Repair)
- Internal Taps**
- 2 Ports
 - 4 Ports
 - 6 Ports
 - 8 Ports
 - 12 Ports
- Splitters**
- Click
 - Zone
 - Unknown
- Additional Cable Stack**
- Additional Cable Stack
- Taps**
- 2 Ports
 - 4 Ports
 - 6 Ports
 - 8 Ports
 - 12 Ports
- Mainline Cables**
- 11
 - 4'
 - 6'
 - 8'
 - 12'
 - 24'
 - 48'
 - 72'
 - 96'
 - 144'
 - 216'
 - 288'
 - 432'

PROPOSED FIBER INSTALLATION PLANS
 SYMBOL REFERENCE LEGEND

SECTOR: NWCCHIL2068
 Printed: 4/2/2025
 Time: 3:29 PM

SHEET: **L1**

SUBMITTED FOR PERMITTING

| REVISIONS | |
|-----------|----------|
| / | 24 No. |
| / | 24 No. |
| / | 24 No. |
| / | 24 No. |
| / | 24 No. |



SUBMITTED FOR PERMITTING

13 Broadband | 602 High Point Lane | Cary, NC 27513 | (919) 470-0400 | Fax: 400-400-1300 | 13broadband.com

1. See Sheet 071 for typical road crossing and bore pit details.
2. Method of conduit installation shall be determined by the contractor. Method of directional boring or trenching shall be determined by the contractor. SPECIAL PERMITTING COMMITMENTS (see sheet 071).
3. Additional conduit locations (other than primary) are shown for reference. All conduit locations shall be shown on the general bore path as the Primary Duct.

PROJECT ENGINEER:

Troy Nostman

REVISIONS

| | | | |
|---|-----|--|-----|
| / | 724 | | No. |
| / | 724 | | No. |
| / | 724 | | No. |
| / | 724 | | No. |
| / | 724 | | No. |

PROPOSED FIBER INSTALLATION PLANS
 FIBER INSTALLATION PLAN MAPS
 Printed: 4/2/2025
 Time: 3:35 PM

SECTOR: NWCHIL2068

SHEET:

D2



**Facilities leaving project boundaries shown only for reference.
 Only facilities entirely inside of project boundaries to be considered part of the project scope unless otherwise specified.**

| REVISIONS | |
|-----------|------------|
| / | 7/24 No. |
| / | 7/24 No. |
| / | 7/24 No. |
| / | 7/24 No. |
| / | 7/24 No. |

SHEET NOTES:
 PCS USA Commercial Equalization Overlay
 SCALE: 1/8" = 50' SET FROM
 1. See Sheet B17 for typical road crossing details.
 2. Method of conduit installation shall be determined by the contractor and shall be OTHERWISE NOTED ON THE PLANS OR SPECIAL PERMITTING COMMITMENTS (See Sheet A1).
 3. Additional conduit locations (other than those shown) shall be determined by the contractor. ONLY Additional ducts shall follow the same general bore-path as the Primary Duct.
PROJECT ENGINEER:



**Facilities leaving project boundaries shown only for reference.
 Only facilities entirely inside of project boundaries to be considered part of the project scope unless otherwise specified.**

SUBMITTED FOR PERMITTING

SCALE: 1" = 50 FEET
FIG. 103 CONFORMANCE STANDARDS CONC.
 1. See SPEC SHEET 103 for typical road crossing and bore pit details.
 2. Method of conduit installation shall be either directional bore or trenching, unless otherwise specified in the SPECIAL PERMITTING COMMITMENTS (See Sheet 101).
 3. Additional conduit locations (other than Primary) are shown as a guide for re-construction and shall be shown on the same general bore plan as the Primary Duct.

PROJECT ENGINEER:
 Troy Mosman

REVISIONS

| | | | |
|---|-----|--|-----|
| / | 724 | | No. |
| / | 724 | | No. |
| / | 724 | | No. |
| / | 724 | | No. |
| / | 724 | | No. |



**Facilities leaving project boundaries shown only for reference.
 Only facilities entirely inside of project boundaries to be considered part of the project scope unless otherwise specified.**

SUBMITTED FOR PERMITTING



SHEET NOTES:
 1. See Sheet D17 for typical road crossing and bore pit details.
 2. Method of conduit installation shall be determined by the contractor. ALL WORK SHALL BE IN ACCORDANCE WITH THE STANDARD SPECIFICATIONS FOR ROAD AND UTILITY CONSTRUCTION, 2011 EDITION, WITH THE LATEST REVISIONS. SPECIAL PERMITTING COMMITMENTS (See Sheet N).

PROJECT ENGINEER:
 Troy Nolesman

| REVISIONS | |
|-----------|------------|
| / | / 24 No. |
| / | / 24 No. |
| / | / 24 No. |
| / | / 24 No. |
| / | / 24 No. |

PROPOSED FIBER INSTALLATION PLANS
FIBER INSTALLATION PLAN MAPS

Printed: 4/2/2025
 Time: 3:38 PM
 SECTOR: NWC HILL 2068

SHEET:
D5



**Facilities leaving project boundaries shown only for reference.
 Only facilities entirely inside of project boundaries to be considered part of the project scope unless otherwise specified.**

SUBMITTED FOR PERMITTING



SCALE: 1"=50'-0" (AS SHOWN)
 PCS: USA, Coaxial, Equidistant Coax.
SHEET NOTES:
 1. Fiber cables and taps are shown as offset from proposed conduits for compatibility with proposed conduit.
 2. Conduits shall field verify all dimensions prior to installing fiber cable.
 3. See Sheet H1 for installed fiber cable stack requirements.

PROJECT ENGINEER:
Troy Mostman

| REVISIONS | |
|-----------|------------|
| / | / 24 No. |
| / | / 24 No. |
| / | / 24 No. |
| / | / 24 No. |
| / | / 24 No. |

PROPOSED FIBER INSTALLATION PLANS
FIBER INSTALLATION PLAN MAPS
 Printed: 4/2/2025
 Time: 3:43 PM

SECTOR: NWCHIL2068

SHEET: **F1**

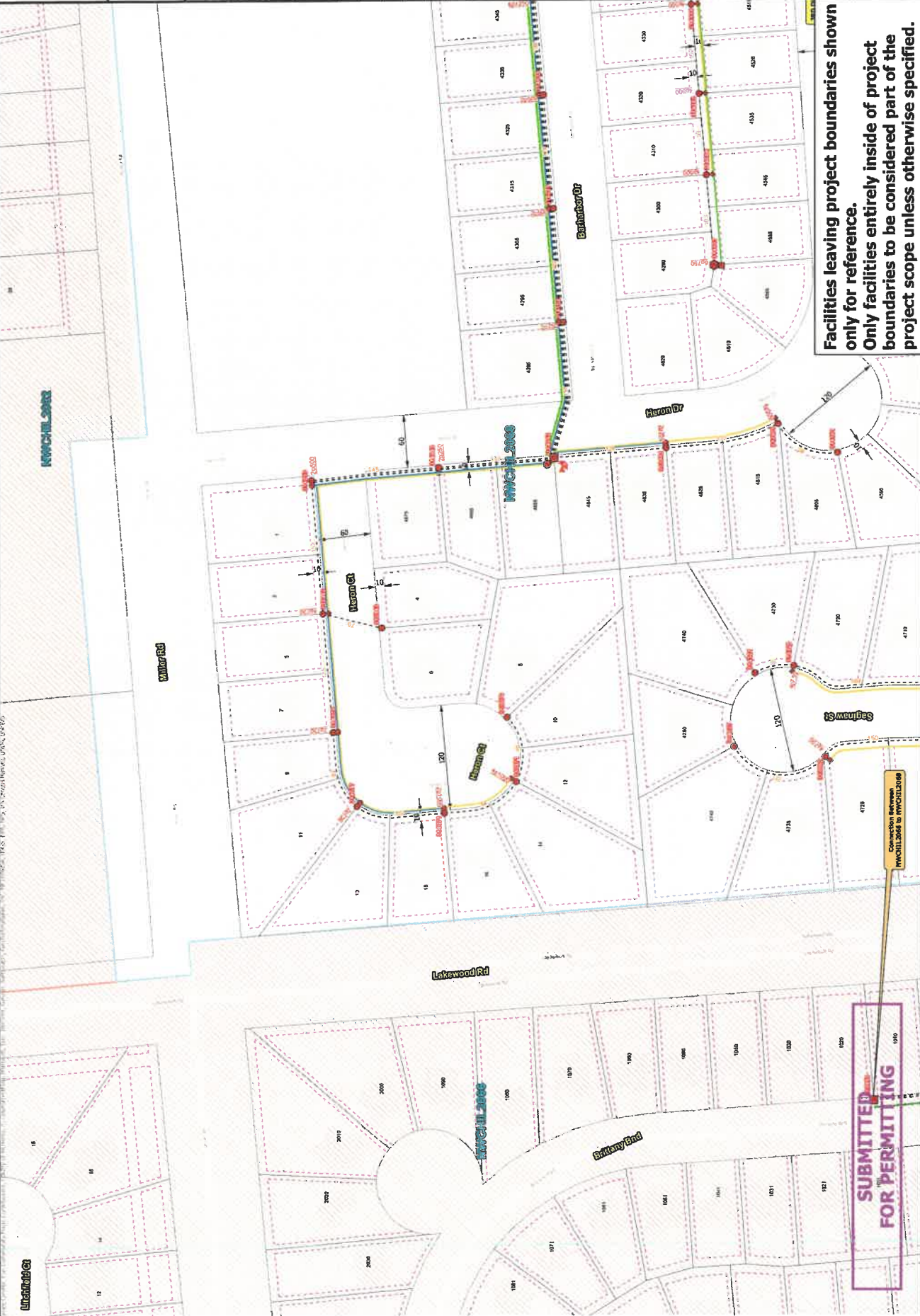

**Facilities leaving project boundaries shown only for reference.
 Only facilities entirely inside of project boundaries to be considered part of the project scope unless otherwise specified.**

SUBMITTED FOR PERMITTING
 Connection Between
 NWCHIL2068 to NWCHIL2068



PCS USA Commercial Subdivision Code
SHEET NOTES:
 1. Fiber cables and legs are shown as offset from proposed conduit for compatibility with proposed conduit.
 2. Conductor shall hold walls, all dimensions are to existing fiber cable.
 3. See Sheet 411 for installed fiber cable stack requirements.

PROJECT ENGINEER:
 Troy Mosiman

| REVISONS |
|-------------------|
| / 724 No. _____ |
| / 724 No. _____ |
| / 724 No. _____ |
| / 724 No. _____ |
| / 724 No. _____ |

PROPOSED FIBER INSTALLATION PLANS
FIBER INSTALLATION PLAN MAPS
 Printed: 4/2/2025
 Time: 3:43 PM

SECTOR: NWCHIL2068

SHEET:
F2



**Facilities leaving project boundaries shown only for reference.
 Only facilities entirely inside of project boundaries to be considered part of the project scope unless otherwise specified.**

SUBMITTED FOR PERMITTING



SCALE: 1"=50 FEET
 NCS - US Customary Standard Units
 THESE PLANS ARE TO BE USED FOR CONSTRUCTION OF THE PROJECT.
 1. Fiber cables and trays are shown as offset from proposed conduit for cartographic clarity. The actual fiber shall be installed with proposed conduit.
 2. Contractor shall field verify all dimensions prior to installing fiber cable.
 3. See Sheet M1 for finished fiber cable slack requirements.

PROJECT ENGINEER:
 Troy Mosiman

| REVISIONS | |
|-----------|----------|
| / | 74 No. |
| / | 74 No. |
| / | 74 No. |
| / | 74 No. |
| / | 74 No. |

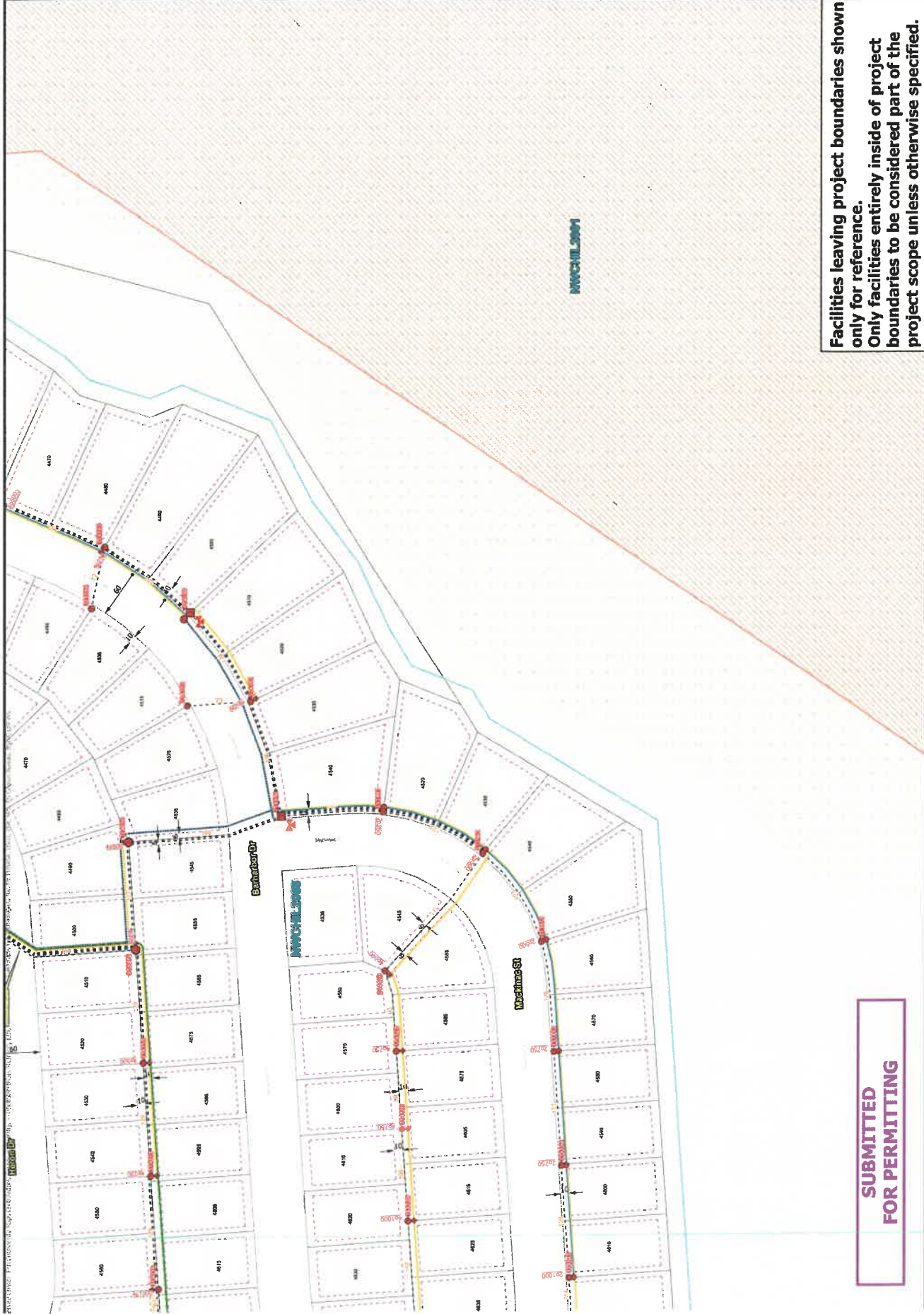

**Facilities leaving project boundaries shown only for reference.
 Only facilities entirely inside of project boundaries to be considered part of the project scope unless otherwise specified.**

SUBMITTED FOR PERMITTING

SCALE: 1"=50 FEET
 0 25 50 75 100 Feet

FOR OFFICIAL USE ONLY
 ALL RIGHTS RESERVED
 1. Fiber cables and fiber optic components are shown as offset from proposed conduit for cartographic representation only. Fiber shall be installed in accordance with applicable industry standards.
 2. See Sheet N1 for installed fiber cable slack requirements.

PROJECT ENGINEER:
 Troy Moshman

REVISIONS
 / /24 / No. _____
 / /24 / No. _____
 / /24 / No. _____
 / /24 / No. _____
 / /24 / No. _____



**Facilities leaving project boundaries shown only for reference.
 Only facilities entirely inside of project boundaries to be considered part of the project scope unless otherwise specified.**

SUBMITTED FOR PERMITTING

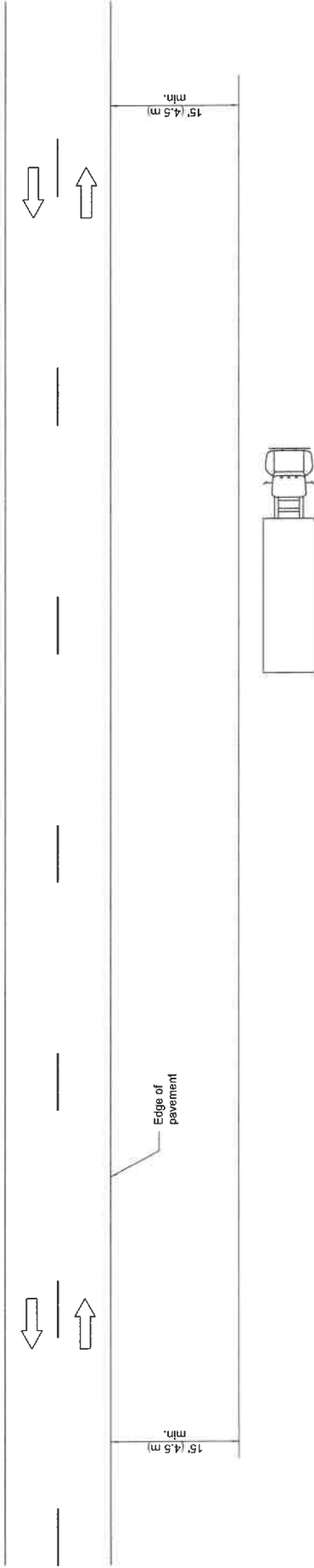

TYPICAL APPLICATIONS

- Landscaping work
- Utility work
- Fencing contracts and maintenance
- Cleaning culverts

GENERAL NOTES

This Standard is used where at all times all vehicles, equipment, workers or their activities are more than 15' (4.5 m) from the edge of pavement.

When the work operation requires that two or more work vehicles cross the 15' (4.5 m) clear zone in any one hour, traffic control shall be according to Standard 701006.

All dimensions are in inches (millimeters) unless otherwise shown.

Illinois Department of Transportation

ISSUED 1-1-47

APPROVED January 1, 2009

ENGINEER OF OPERATIONS

APPROVED January 1, 2009

ENGINEER OF DESIGN AND ENVIRONMENT

| DATE | REVISIONS |
|--------|-------------------------------------|
| 1-1-09 | Switched units to English (metric). |
| 1-1-05 | Revised title and notes. |

**OFF-RD OPERATIONS,
2L, 2W, MORE THAN
15' (4.5 m) AWAY**

STANDARD 701001-02

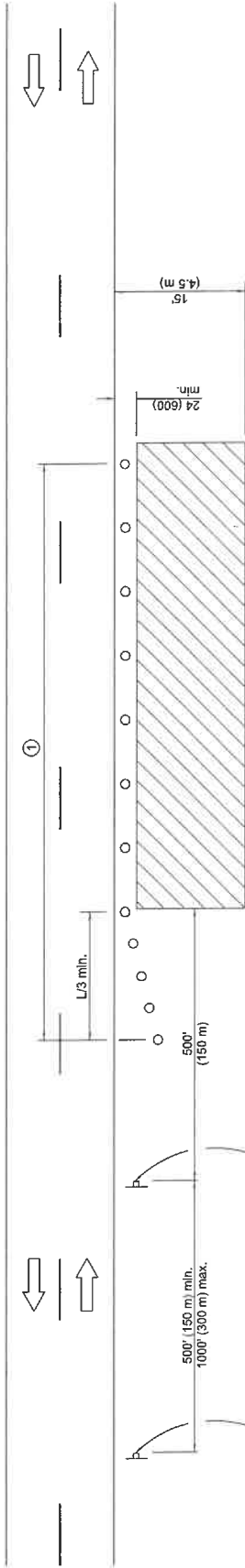

For contract construction projects



W20-1103(0)-48

For maintenance and utility projects



W20-1(0)-48



W21-1(0)-48

TYPICAL APPLICATIONS

- Utility operations
- Culvert extensions
- Side slope changes
- Guardrail installation and maintenance
- Delimitator installation
- Landscaping operations
- Shoulder repair
- Sign installation and maintenance

SYMBOLS

- Work area
- Sign
- Cone, drum or barricade

GENERAL NOTES

This Standard is used where any vehicles, equipment, workers or their activities will encroach in the area 15' (4.5 m) to 24' (600) from the edge of pavement.

Calculate L as follows:

| SPEED LIMIT | FORMULAS |
|------------------------------|------------------------|
| English | (Metric) |
| 40 mph (70 km/h) or less: | $L = \frac{WS^2}{60}$ |
| 45 mph (80 km/h) or greater: | $L = \frac{WS^2}{150}$ |
| | $L = 0.65(W)(S)$ |

W = Width of offset in feet (meters).
 S = Normal posted speed mph (km/h).

All dimensions are in inches (millimeters) unless otherwise shown.

OFF-RD OPERATIONS, 2L, 2W, 15' (4.5 m) TO 24" (600 mm) FROM PAVEMENT EDGE

| DATE | REVISIONS |
|--------|--|
| 1-1-14 | Revised workers sign number to agree with current MUTCD. |
| 1-1-13 | Omitted text 'WORKERS' sign. |

STANDARD 701006-05

Illinois Department of Transportation
 APPROVED *[Signature]* January 1, 2014
 ENGINEER OF SAFETY ENGINEERING
 APPROVED *[Signature]* January 1, 2014
 ENGINEER OF DESIGN AND ENVIRONMENT
 ISSUED 1-1-97

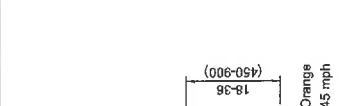
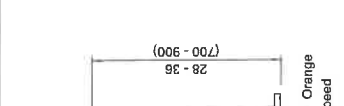
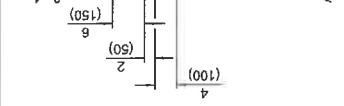
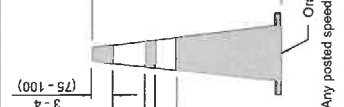
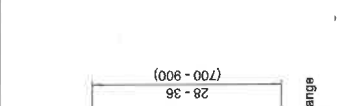
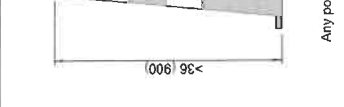
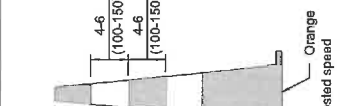
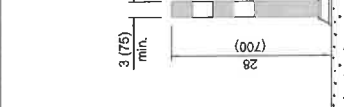
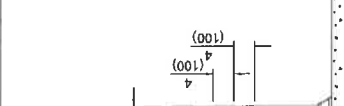
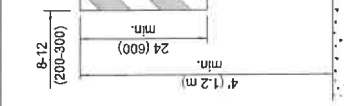
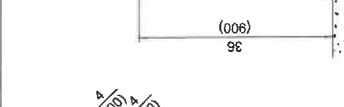
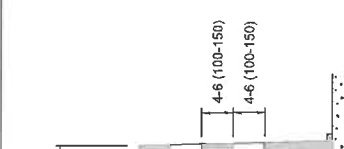

DAYTIME USE
Posted speed < 45 mph
Orange
Any posted speed

DAY OR NIGHTTIME USE
Any posted speed
Orange
Any posted speed

CONES

TUBULAR MARKER



VERTICAL PANEL POST MOUNTED

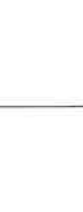
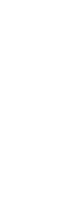

DRUM

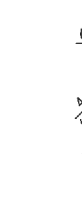
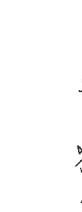
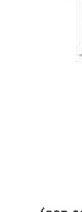
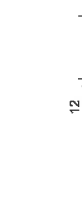

TYPE I BARRICADE

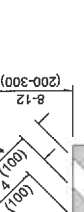
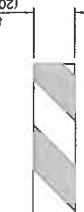
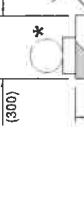

TYPE II BARRICADE

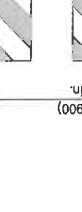
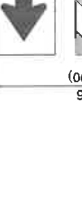
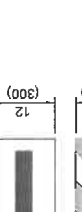
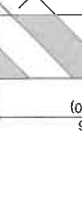

TYPE III BARRICADE

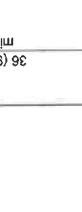
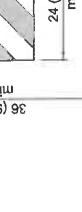
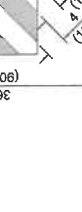
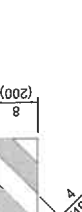
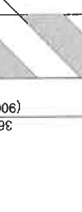

DIRECTION INDICATOR BARRICADE

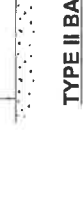
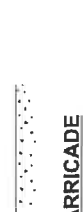
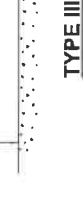
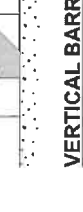

VERTICAL BARRICADE

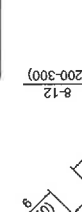

DETECTABLE PEDESTRIAN CHANNELIZING BARRICADE

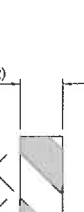

GENERAL NOTES

All heights shown shall be measured above the pavement surface.
All dimensions are in inches (millimeters) unless otherwise shown.

* Warning lights (if required)

TRAFFIC CONTROL DEVICES

| DATE | REVISIONS |
|--------|--|
| 1-1-25 | Updated Temporary Rumble Strip Detail (sht. 3). |
| 1-1-24 | Revised Type III Barricade notes (sht. 3) & moved warning light on post mounted signs to top center. |

STANDARD 701901-10

(Sheet 1 of 3)

Illinois Department of Transportation
APPROVED January 1, 2025
ENGINEER OF SAFETY PROJ. AND ENGINEERING
APPROVED January 1, 2025
ENGINEER OF DESIGN AND ENVIRONMENT

ISSUED 1-1-43

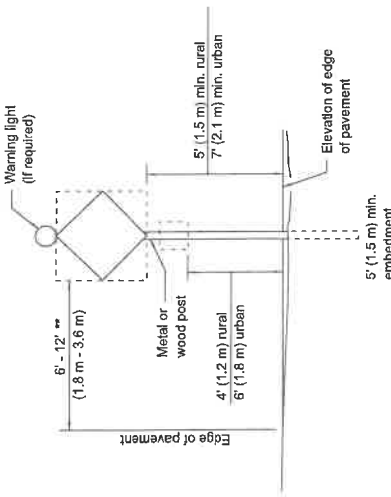

POST MOUNTED SIGNS

** When curb or paved shoulder are present this dimension shall be 24' (600) to the face of curb or 6' (1.8 m) to the outside edge of the paved shoulder.

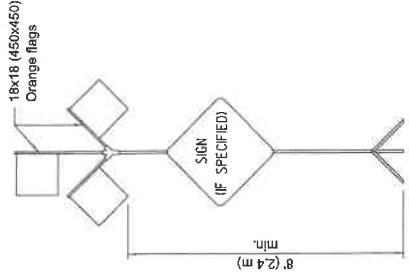

HIGH LEVEL WARNING DEVICE

SIGNS ON TEMPORARY SUPPORTS

*** When work operations exceed four days, this dimension shall be 5' (1.5 m) min. If located behind other devices, the height shall be sufficient to be seen completely above the devices.

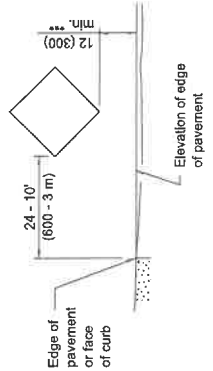

ROAD CONSTRUCTION NEXT X MILES
G20-1104(0)-6036

END CONSTRUCTION
G20-1105(0)-6024

This signing is required for all projects 2 miles (3200 m) or more in length.

ROAD CONSTRUCTION NEXT X MILES sign shall be placed 500' (150 m) in advance of project limits.

END CONSTRUCTION sign shall be erected at the end of the job unless another job is within 2 miles (3200 m).

Dual sign displays shall be utilized on multi-lane highways.

WORK LIMIT SIGNING

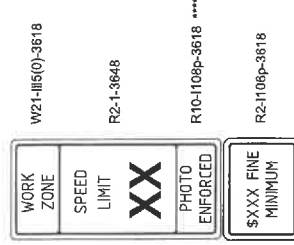

Sign assembly as shown on Standards or as allowed by District Operations.



This sign shall be used when the above sign assembly is used.

HIGHWAY CONSTRUCTION SPEED ZONE SIGNS

**** R10-1108p shall only be used along roadways under the jurisdiction of the State.

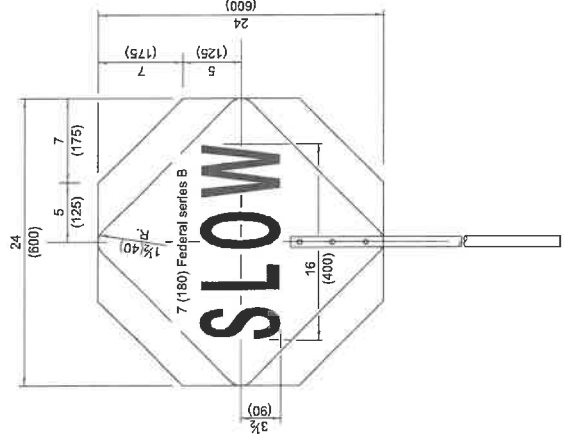
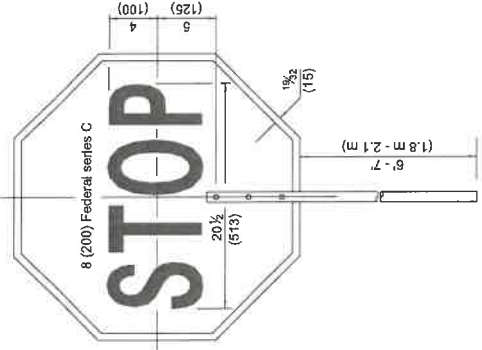

FLAGGER TRAFFIC CONTROL SIGN

Illinois Department of Transportation

APPROVED [Signature] 1 January 1, 2025

ENGINEER OF SAFETY PROJECT AND ENGINEERING

APPROVED [Signature] 1 January 1, 2025

ENGINEER OF DESIGN AND ENVIRONMENT

ISSUED 1-1-13

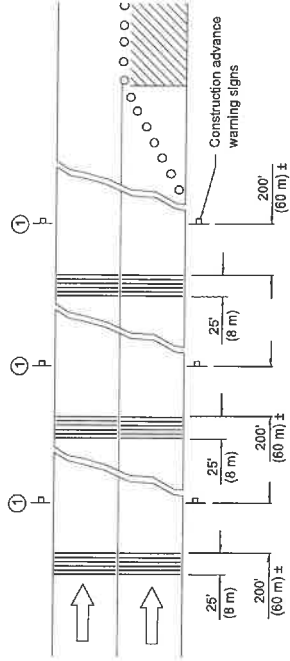

① This sign shall be omitted when median width is less than 10' (3 m).

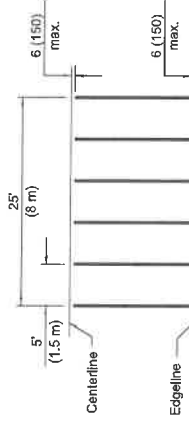

TYPICAL INSTALLATION

TEMPORARY RUMBLE STRIPS

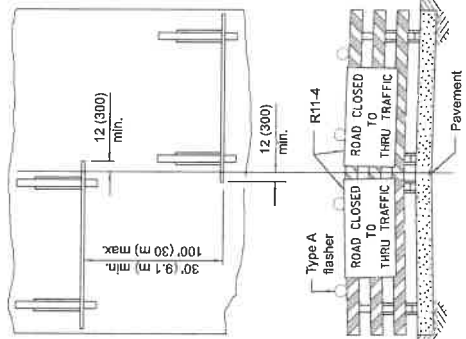

ROAD CLOSED TO THRU TRAFFIC
 ReflectORIZED striping shall appear on both sides of the barricades.

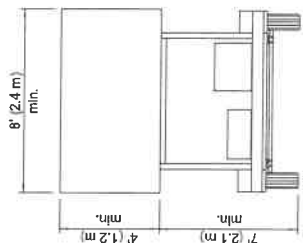

**TYPE C
TRAILER
MOUNTED**

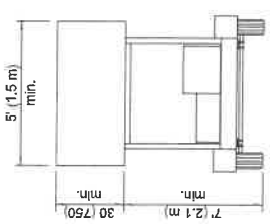

**TYPE B
ROOF OR TRAILER
MOUNTED**

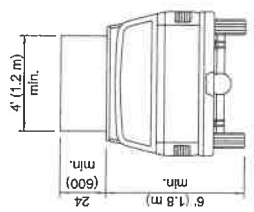

**TYPE A
ROOF
MOUNTED**

ARROW BOARDS

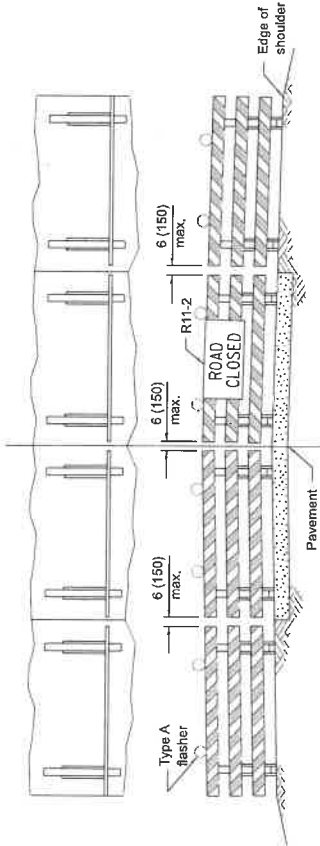

ROAD CLOSED TO ALL TRAFFIC
 ReflectORIZED striping may be omitted on the back side of the barricades.

**TYPICAL APPLICATIONS OF
TYPE III BARRICADES CLOSING A ROAD**

If a Type III barricade with an attached sign panel which meets NCHRP 350 or MASH is not available, the sign may be mounted on an NCHRP 350 or MASH temporary sign support directly in front of the barricade.

Illinois Department of Transportation
 ISSUED 1-1-13
 APPROVED [Signature] 2026
 ENGINEER OF SAFETY/PROJECT ENGINEERING
 APPROVED [Signature] 2026
 ENGINEER OF DISTRICT ENVIRONMENT

**TRAFFIC CONTROL
DEVICES**

STANDARD 701901-10